

Computational Modeling, Artificial Intelligence Research

Critical Zone Hydrology

- **Dr. Hannes Bauser**
- Assistant Professor
- Department of Geoscience
- Email: hannes.bauser@unlv.edu
- Website: <https://geoscience.unlv.edu/people/department-faculty/hannes-bauser/>

Expertise

- Vadose Zone Hydrology and Soil Physics
- Hydrologic Modeling
- Data Assimilation
- Machine Learning

Hydrologic Scaling Challenge

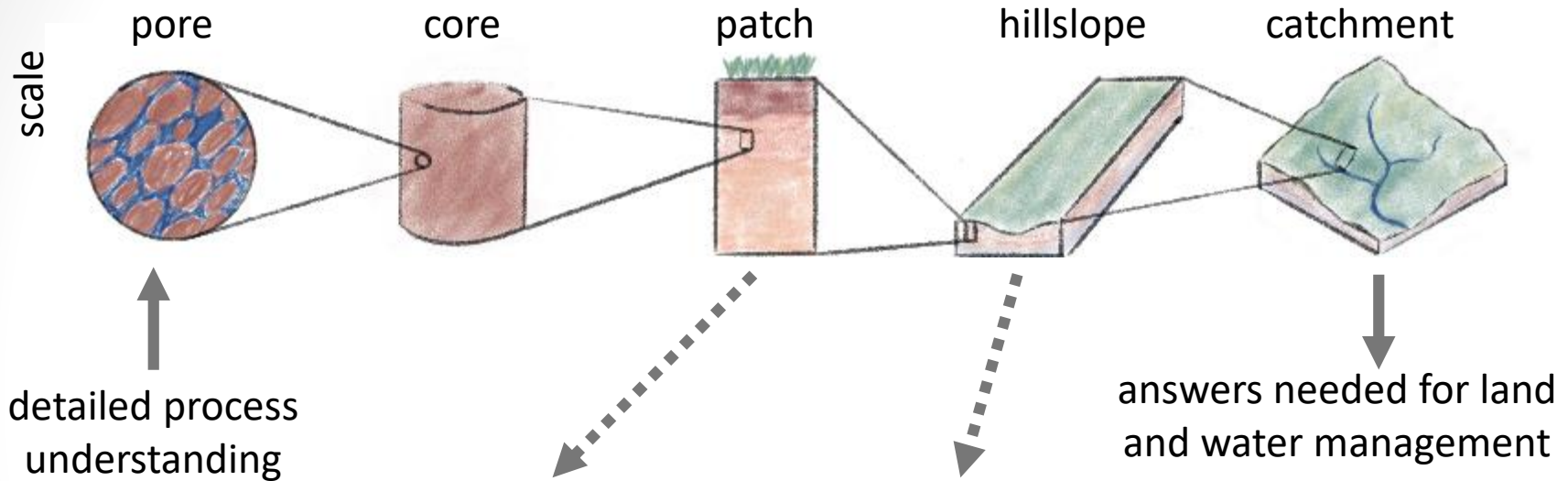

detailed process understanding

answers needed for land and water management

Collaboration with the Desert Research Institute for access to the [SEPHAS Lysimeters](#) in Boulder City.



Collaboration with the University of Arizona for access to the [Landscape Evolution Observatory](#) at Biosphere 2.

How can we use data science (e.g., data assimilation, machine learning) to combine process understanding and data to solve the hydrologic scaling challenge?

Theoretical and Computational Condensed Matter and Materials Physics

Dr. Changfeng Chen

Department of Physics and Astronomy

Phone: 702-895-4230

Email: chen@physics.unlv.edu

Expertise

- Novel states of matter: topological insulators and semimetals
- Superior bonding structures: superhard and supertough materials
- Intriguing quantum phenomena: superconductivity and magnetism
- Extreme mechanics: stress responses to complex large strains
- Ultimate thermodynamics: materials inside Earth and other planets

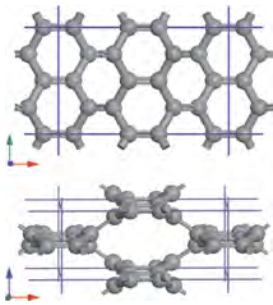

Nodal-ring Dirac semimetal states identified in bco-C₁₆ crystal [Wang, Weng, Nie, Fang, Kawazoe, Chen, *Phys. Rev. Lett.* 116, 195501 (2016)].

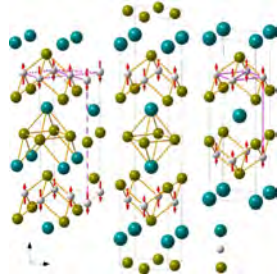

Magnetic Dirac materials CaMnBi₂ and SrMnBi₂ [Zhang, et al., *Nature Commun.* 7, 13833 (2016)].

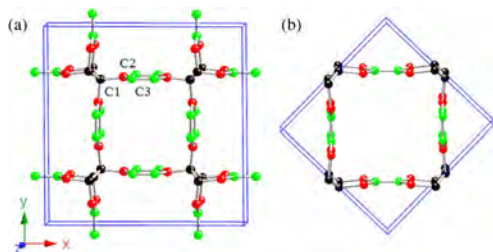

Nodal-net Dirac semimetal states in a graphene network structure [Wang, Nie, Weng, Kawazoe, Chen, *Phys. Rev. Lett.* 120, 026402 (2018)].

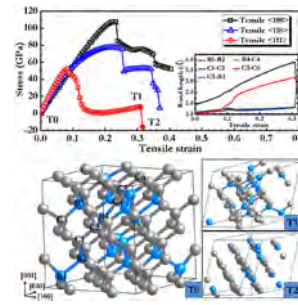

Superhard B₃C in diamond structure [Zhang, et al., *Phys. Rev. Lett.* 114, 015502 (2015)].

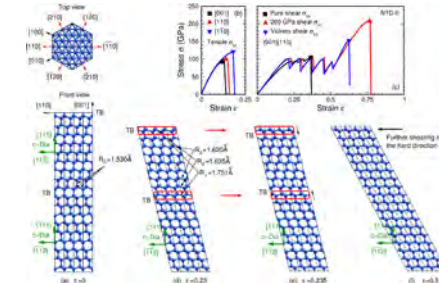

Extreme mechanics of nanotwinned diamond [Li, Sun, Chen, *Phys. Rev. Lett.* 117, 116103 (2016)].

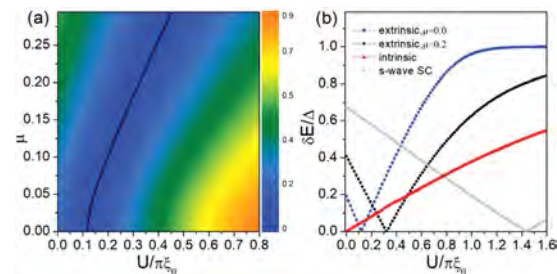

Kondo physics in 2D topological superconductors [Wang, et al., *Phys. Rev. Lett.* 122, 087001 (2019)].



Helium-bearing compound FeO_2He predicted to stabilize at deep-Earth conditions [Zhang, et al., *Phys. Rev. Lett.* **121**, 255703 (2018)].

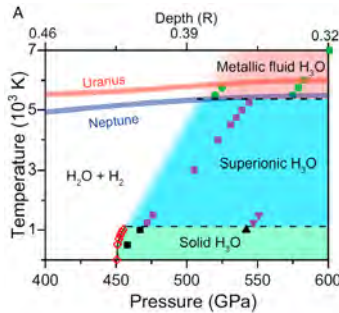

Prediction of novel H_3O and implications for the magnetic fields of Uranus and Neptune [Huang, et al., *Proc. Natl. Acad. Sci.* **117**, 5638 (2020)].

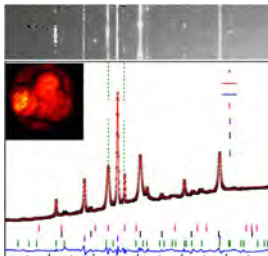

Pressure-stabilized divalent ozonide CaO_3 and its impact on Earth's oxygen cycles [Wang, et al., *Nature Commun.* **11**, 4702 (2020)].

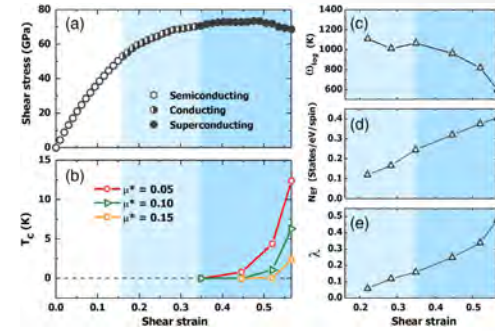
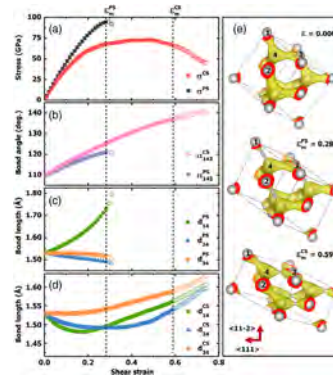

Metallization and superconductivity in diamond [Liu, et al., *Phys. Rev. Lett.* **123**, 195504 (2019); *Phys. Rev. Lett.* **124**, 147001 (2020)].

Further Reading (selected papers by Chen Group, 2015-2020)

Anomalous Stress Response of Ultrahard WB_n Compounds, Li, Zhou, Zheng, Ma, Chen, *Phys. Rev. Lett.* **115**, 185502 (2015).

Ultralow-Frequency Collective Compression Mode and Strong Interlayer Coupling in Multilayer Black Phosphorus, Dong, et al., *Phys. Rev. Lett.* **116**, 087401 (2016).

Extraordinary Indentation Strain Stiffening Produces Superhard Tungsten Nitrides, Lu, Li, Ma, Chen, *Phys. Rev. Lett.* **119**, 115503 (2017).

Xenon iron oxides predicted as potential Xe hosts in Earth's lower mantle, Peng, Song, Liu, Li, Miao, Chen, Ma, *Nature Commun.* **11**, 5227 (2020).

Zhonghai Ding

- Professor of Mathematics
Department of Mathematical Sciences
- Ph.D. in Mathematics
Texas A&M University, College Station, Texas
- CDC 1004, Zhonghai.Ding@unlv.edu
- <https://faculty.unlv.edu/zding/>



Areas of Expertise

- Control Theory
- Partial Differential Equation
- Mathematical Modeling
- Numerical Computation

Research Summary:

Dr. Ding's research interests are in mathematical modeling and analysis, control, and computation of problems arising from real applications such as nematic liquid crystals, suspension bridge systems, shape memory alloys, oxidation of metal matrix composites, control of dynamical systems, etc.. These systems are governed by linear or nonlinear partial differential equations. Dr. Ding's research focus on analyzing system behaviors, developing numerical methods for solutions, and investigating related control issues.

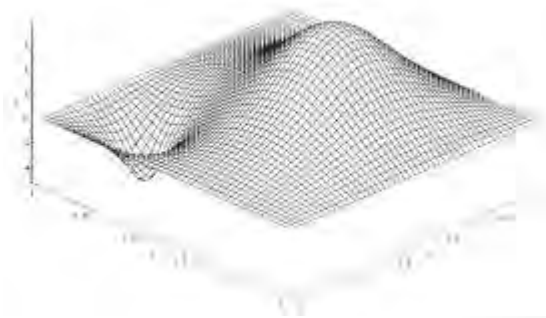
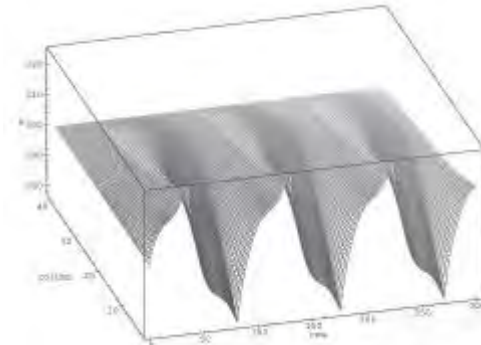

Island – Quantum computing, quantum sensing



The Nanoscale Physics Group @ UNLV

Areas of Research

- Nanotechnology, device physics
- Photodetection and quantum sensing
- Quantum computing, topological qubits
- Non-equilibrium, driven systems
- Superconductivity, proximity effects
- Low dimensional materials

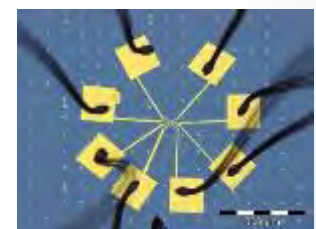
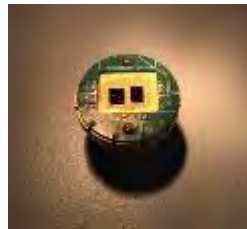
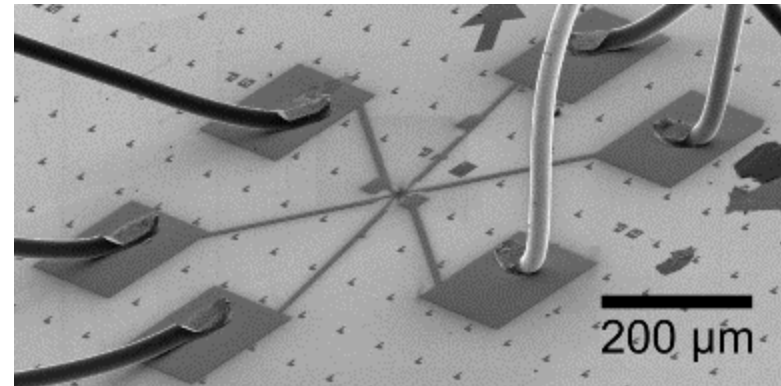

Island – Quantum computing, quantum sensing

Quantum computing:
Topological phases for fault-tolerant, universal quantum computing.

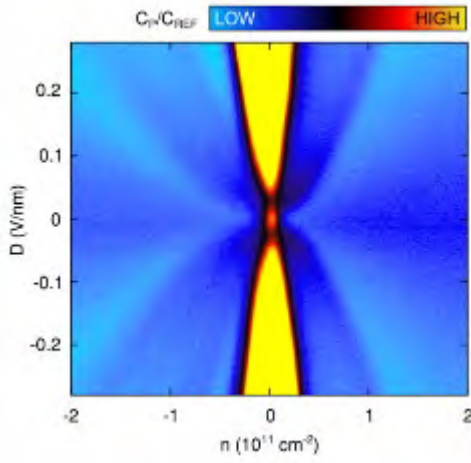
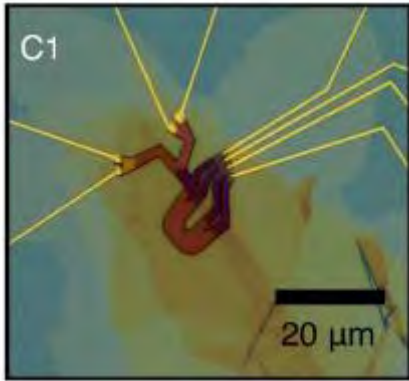

Island, J. O., et al. *Nature* **571** (2019): 85–89.

Industry-disruptive photodetectors: Ultra-sensitive phototransistors designed with 2D materials and heterostructures.

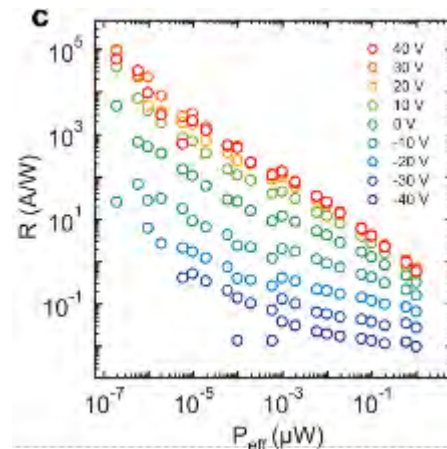
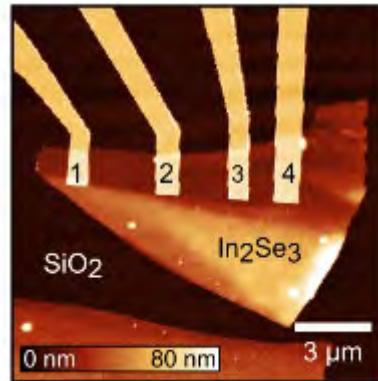

Island, J. O., et al. *Nano Letters* **15** (2015): 7853-7858.

Transient phases of driven systems: Non-equilibrium response of pumped nanomaterials below the diffraction limit.

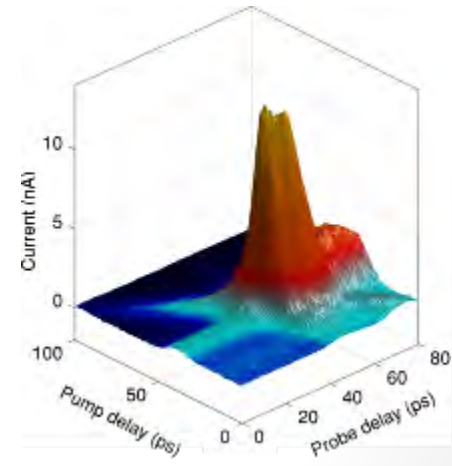
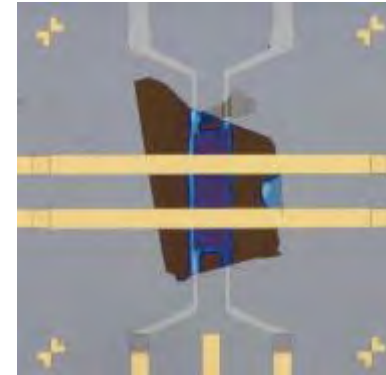

Island – Quantum computing, quantum sensing

Journal publications:

Spin-orbit-driven band inversion in bilayer graphene by van der Waals proximity effect

J.O. Island, X. Cui, C. Lewandowski, J.Y. Khoo, E.M. Spanton, H. Zhou, D. Rhodes, J.C. Hone, T. Taniguchi, K. Watanabe, L.S. Levitov, M.P. Zaletel, A.F. Young, *Nature*, **571**, 85-89 (2019). (arXiv)

Enhanced superconductivity in atomically thin TaS₂

E. Navano-Moiatalla*, J.O. Island*, S. Manas-Valero, E. Pinilla-Cienfuegos, A. Castellanos-Gomez, J. Queieda, G. Rubio-Bollinger, L. Chirulli, J.A. Silva-Guilin, N. Agrat, G.A. Steele, F. Guinea, H.S.J. van der Zant, E. Coronado, *Nature Communications*, **15**, 7853 (2016). (arXiv)

Proximity-induced Shiba states in a molecular junction

J. O. Island, R. Gaudenzi, J. de Bruijckere, E. Burzuri, C. Franco, M. Mas-Torrent, C. Rovira, J. Veciana, T. M. Klapwijk, R. Aguado, H.S.J. van der Zant, *Physical Review Letters*, **118**, 117001 (2017). (arXiv)

TiS₃ transistors with tailored morphology and electrical properties

J.O. Island, M. Barawi, R. Biele, A. Almazan, J.M. Clamagirand, J.R. Ares, C. Sanchez, H.S.J. van der Zant, J.V. Alvarez, R. D'Agosta, I.J. Ferrer, A. Castellanos-Gomez, *Advanced Materials*, **27**, 2595 (2015). (arXiv)

Environmental instability of few-layer black phosphorus

J.O. Island, G.A. Steele, H.S.J. van der Zant, and A. Castellanos-Gomez, *2D Materials*, **2**, 011002 (2015). (arXiv)

Ultrahigh photoresponse of few-layer TiS₃ nanoribbon transistors

J.O. Island, M. Buscema, M. Barawi, J.M. Clamagirand, J.R. Ares, C. Sanchez, I.J. Ferrer, G.A. Steele, H.S. J van der Zant, and A. Castellanos-Gomez, *Advanced Optical Materials*, **2**, 641 (2014). (arXiv)

Gate controlled photocurrent generation mechanisms in high-gain In₂Se₃ phototransistors

J.O. Island*, S.I. Blanter*, M. Buscema, H.S.J. van der Zant, and A. Castellanos-Gomez, *Nano Letters*, **15**, 7853(2015). (arXiv)

Precise and reversible band gap tuning In single-layer MoSe₂ by uniaxial strain

J.O. Island, A. Kuc, E.U. Diependaal, H.S.J. van der Zant, T. Heine, and A. Castellanos-Gomez, *Nanoscale*, **8**, 2589 (2016). (arXiv)

Scientific Computing and Mathematical Modeling

- **Dr. Jichun Li**
- Full Professor
- Department Mathematical Sciences
- Email: jichun.li@unlv.edu
- Website: <http://faculty.unlv.edu/jichun/>

Expertise

- Computational Electromagnetics: wave propagation in metamaterials, graphene, and other complex media.
- Develop, analyze, and implement various numerical methods for solving various Differential Equations (DEs) in sciences and engineering.
- Machine Learning; Math finance; Numerical Analysis.

Published over 2 books, and over 140 SCI papers

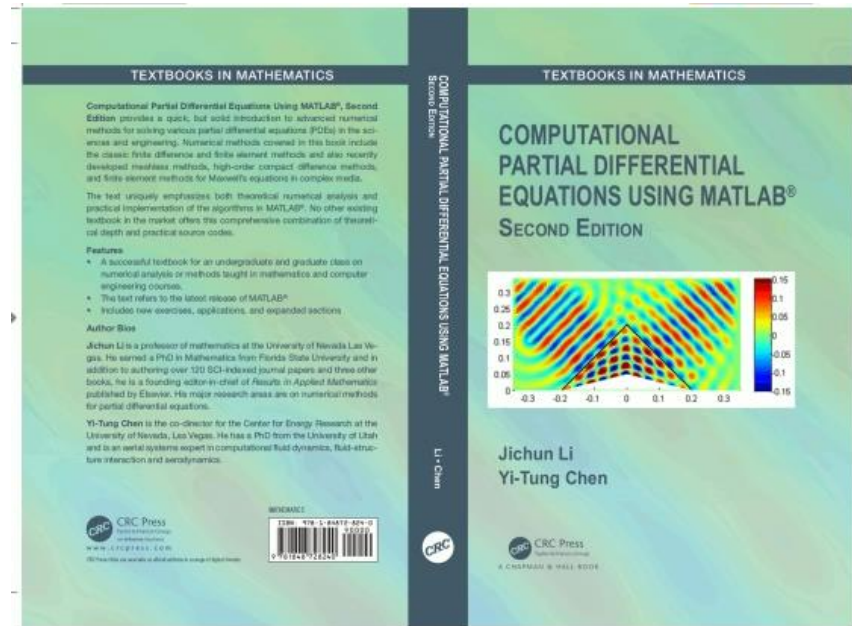
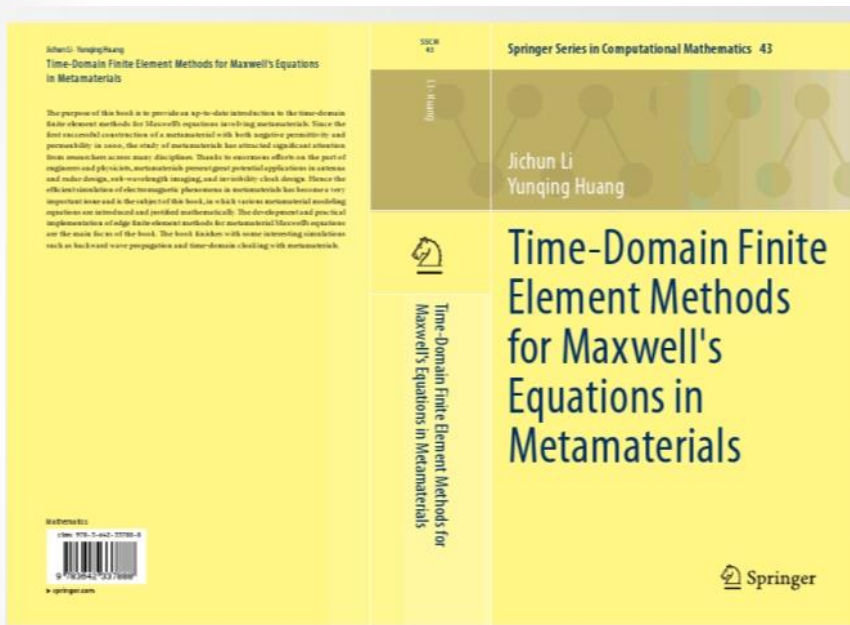

In 2023, ranked #1097 (out of total 1138) in United States and #2638 in the world in The 2nd edition of Research.com ranking of the best scholars in the arena of Mathematics: <https://research.com/scientists-rankings/mathematics/>

Computational Biology

- **Dr. Qian (Chris) Liu**
- Assistant Professor of Nevada Institute of Personalized Medicine (NIPM)
- School of Life Sciences
- Email: qian.liu@unlv.edu
- Website: <https://www.unlv.edu/people/qian-liu>, <https://qgenlab.org>

Expertise

- Deep Learning
- Bioinformatics
- Modification Detection
- Long-read Data Analysis
- RNA-Seq Data Analysis
- Protein Functional Analysis

Research interests

Dr. Liu currently works on the development of deep learning/machine learning-based tools to conduct long-read data analysis.

This includes, but not limited to, the estimation of short tandem repeats, DNA modification detection, RNA modification detection, and RNA-seq data analysis. Besides, Dr. Liu is also interested in functional analysis of proteins.

The ultimate goal of Dr. Liu's research is to accelerate and facilitate genetic discoveries for human disease studies.

Rebecca Martin

- Professor of Astronomy
- BPB 233
- Department of Physics and Astronomy
- Email: Rebecca.martin@unlv.edu

Expertise

- Star and planet formation
- Astrophysical Fluids
- Binary Star Systems
- Planetary System Dynamics

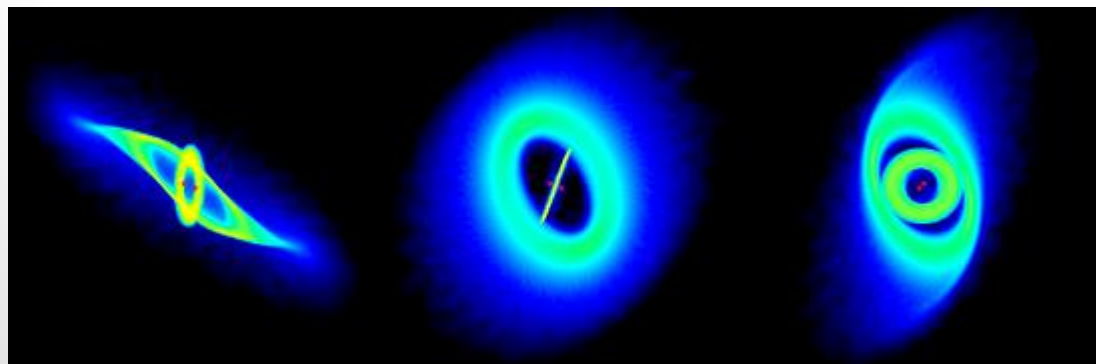
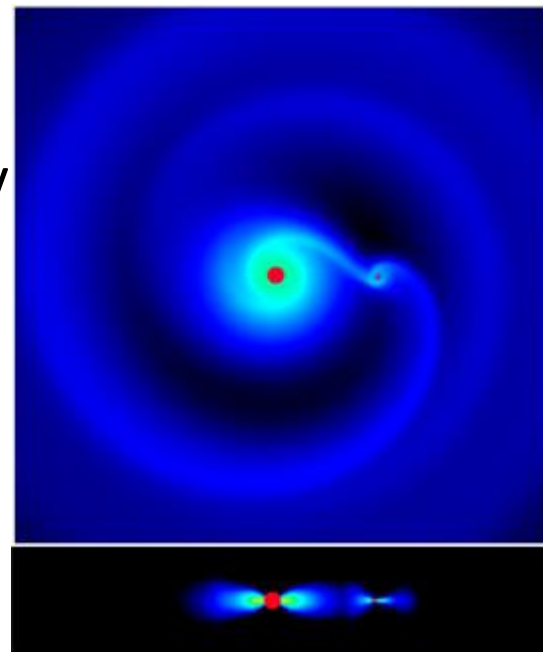

Quantum Information and Quantum Control of Chemical Reactions

Balakrishnan Naduvalath

Department of Chemistry & Biochemistry,
UNLV

Areas of Expertise

- Ultracold Molecules
- Ultracold Quantum Engineered Chemistry
- Quantum control of chemical reactions
- Geometric phase effect in chemistry
- Stereodynamic control of chemical reactions

\$\$\$: NSF, DOD, NASA

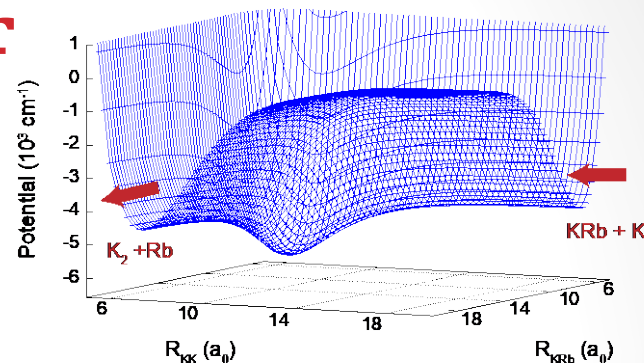

Chemical reaction pathway in ultracold K+KRb collisions. Quantum engineered KRb molecules have been prepared at 300 nK. Ultracold polar molecules such as KRb are potential candidates for quantum computing and quantum information processing.

Controlling reaction outcome through quantum interference

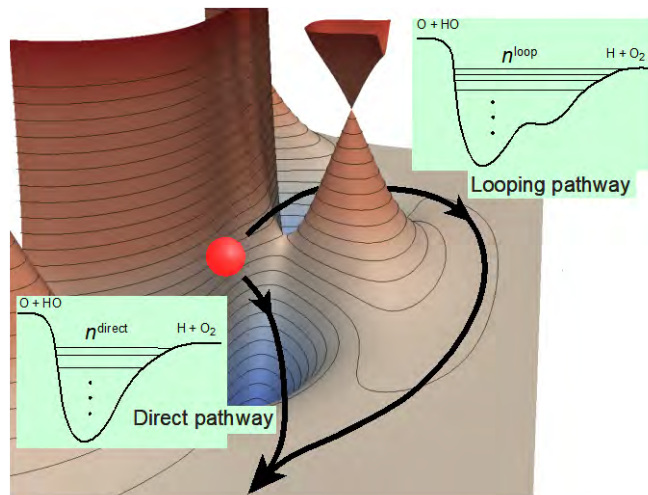

Right panel: The nature of the interference can be controlled by including “geometric phase”. In the image on the right, inclusion of the geometric phase enhances the reactivity. The geometric phase (that correctly describes the sign of the wave function near a conical intersection with an excited electronic state) acts as a “quantum switch” (Hazra, Balakrishnan, and Kendrick, *J. Phys. A* **119**, 12291 (2015))

Left panel: Two paths for a chemical reaction. These two paths can interfere constructively or destructively, maximizing or minimizing the reaction rate. This quantum effect becomes magnified in the ultracold regime (Kendrick, Hazra, and Balakrishnan, *Nature Comm.* **6**, 7918 (2015)).

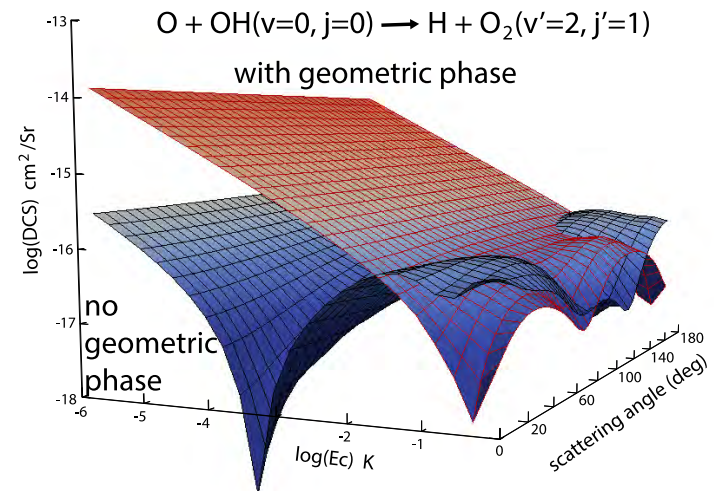

References

- P. G. Jambrina, J. F. E. Croft, H. Guo, M. Brouard, N. Balakrishnan, and F. J. Aoiz, Stereodynamical control of a quantum scattering resonance in cold molecular collisions, *Phys. Rev. Lett.* **123**, 043401 (2019).
- J. F. E. Croft and N. Balakrishnan, Controlling rotational quenching rates in cold molecular collisions, *J. Chem. Phys.* **150**, 164302 (2019).
- K. Hilsabeck, J. Meiser, M. Sneha, N. Balakrishnan, and R. N. Zare, Photon Catalysis of Deuterium iodide photodissociation, *Phys. Chem. Chem. Phys.* **21**, 14195 (2019).
- J. F. E. Croft, N. Balakrishnan, M. Huang, and H. Guo, Unrevealing the stereodynamics of cold controlled HD-H₂ collisions, *Phys. Rev. Lett.* **121**, 113401 (2018). (**Editor's choice**).
- J. F. E. Croft, C. Makrides, M. Li, A. Petrov, B. K. Kendrick, N. Balakrishnan, and S. Kotochigova, Universality and chaoticity in ultracold K+KRb chemical reactions, *Nature Comm.* **8**, 15897 (2017).
- N. Balakrishnan, Perspective: Ultracold molecules and the dawn of cold controlled chemistry, *J. Chem. Phys.* **145**, 150901 (2016).
- B. K. Kendrick, J. Hazra, and N. Balakrishnan, The Geometric Phase Appears in the Ultracold Hydrogen Exchange Reaction, *Phys. Rev. Lett.* **115**, 153201 (2015).
- B. K. Kendrick, J. Hazra, and N. Balakrishnan, The Geometric Phase Controls Ultracold Chemistry, *Nature Communications* **6**, 7918 (2015).

Computational Fluid Dynamics

- **Dr. Monika Neda**
- Professor, Department of Mathematical Sciences
- monika.neda@unlv.edu
- <https://faculty.unlv.edu/neda/>



Expertise

- Computational Fluid Dynamics
- Turbulence
- Numerical Methods for Partial Differential Equations
- Applied Sensitivity Analysis
- STEM education

Simulation of fluid flow: Calculations of drag and lift

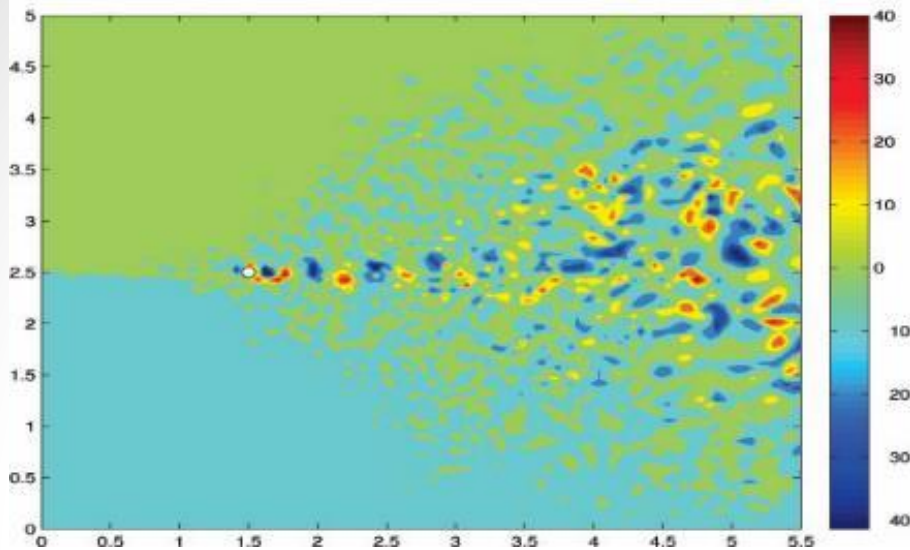

The figure (left side) presents the creation of the vortex street behind an immersed body in a fluid. It can be used to compute drag and lift in aerodynamics, such as drag and lift of aircrafts.

Simulation of fluid flow:
Creation of eddies/vortices
behind the step

The figure (right side)
depicts the creation of the
rotational structures
behind the step as a result
of the interaction of the
fluid with boundaries.

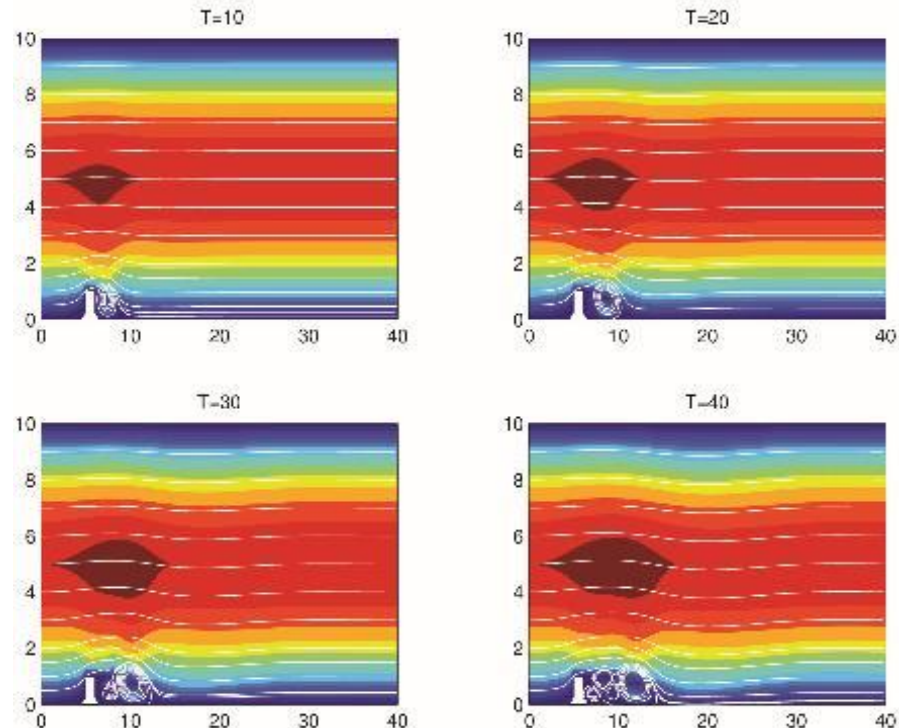

Condensed Matter Theory

- **Dr. Tao Pang**
- Professor of Physics
- Department of Physics and Astronomy
- Email: tao.pang@unlv.edu
- Website: physics.unlv.edu/~pang/



Expertise

- Theoretical and computational studies of novel materials, such as cold atoms and molecules, superconductors and superfluids, and other highly correlated systems.
- Path-integral and diffusion quantum Monte Carlo simulations and other first-principles calculations.
- Functional variation, correlated-basis, mean-field, and other analytical approaches.

Research Methods and Systems Studied

- **Analytical Approach**

Quantum Hall effect; quantum transport phenomena, superconductor-insulator transitions; vibrational modes in glasses; and slow light in cold atoms.

- **Diffusion Quantum Monte Carlo Simulation**

Negative donor centers in semiconductors; hydrogen molecules in confinement; ionic hydrogen clusters; and helium clusters with modified interactions.

- **Path Integral Quantum Monte Carlo Simulation**

Bosons trapped in potential wells in one dimension or two dimensions; Bose-Einstein condensation of cold atoms; and asymmetric distributions of Bose-Einstein condensates of boson mixtures.

An Example: Asymmetry of the Mixed Bose Condensates:

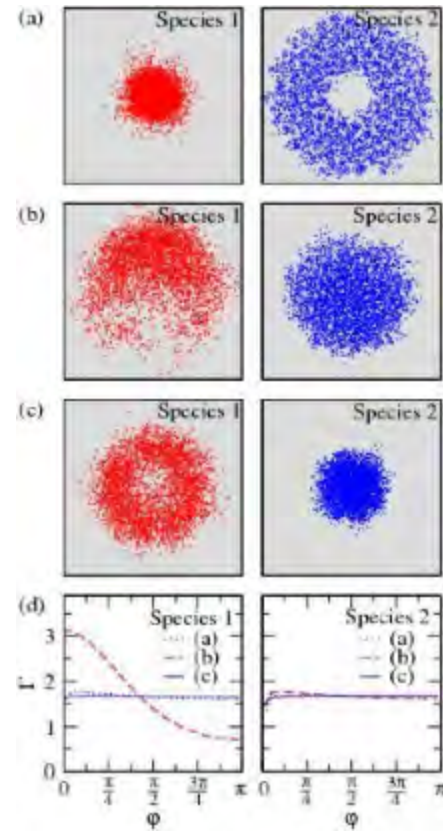
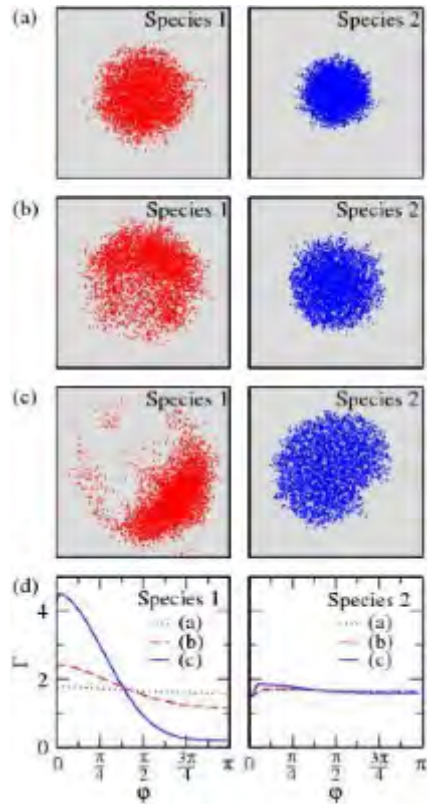

Asymmetric distributions of two Bose-Einstein condensates in the same trap with different cluster parameters.

H. Ma and T. Pang, Phys. Rev. A **70**, 063606 (2004).

Environmental Geochemistry

Dr. Zach Perzan

- Assistant Professor
- Department of Geoscience
- Email: zach.perzan@unlv.edu
- Website: <https://zperzan.github.io/>

Expertise

- Environmental geochemistry
- Surface water-groundwater hydrology
- Machine learning
- Uncertainty quantification
- Managed aquifer recharge



Understanding how hydrologic extremes (droughts and floods) impact water quality

Managed aquifer recharge

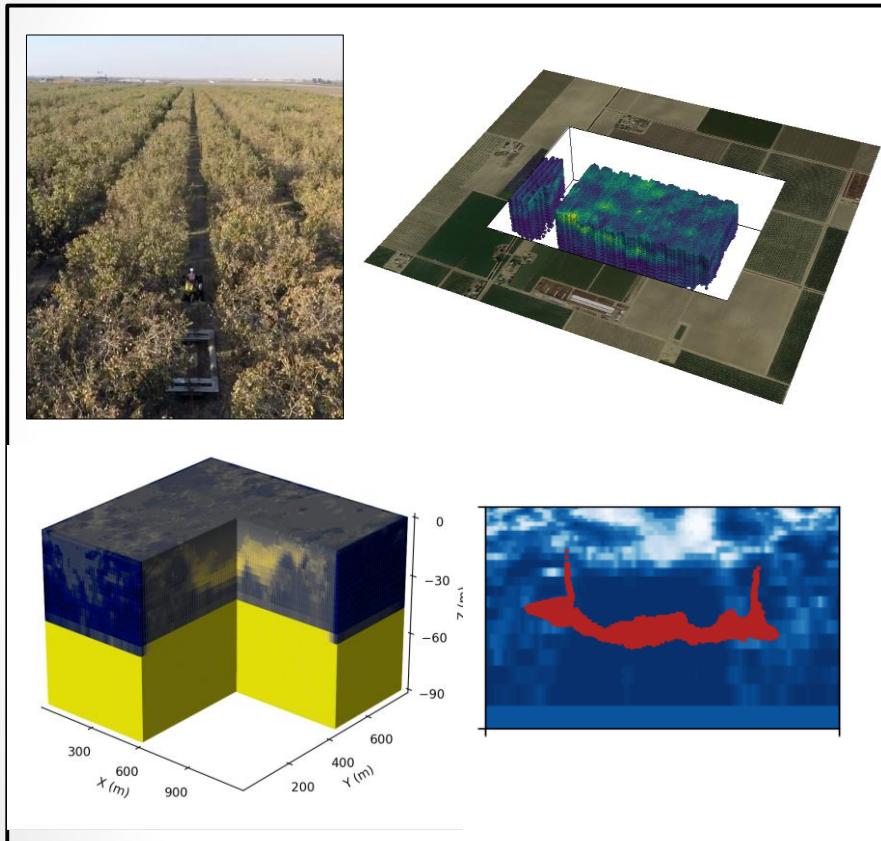

Geophysical surveys (top left) give us a 3D image of the distribution of sand, silt and clay within the subsurface (top right). We can then use hydrologic and geochemical models to understand how water (bottom left) and contaminants (bottom right) move through these sediments during a flood.

Floodplain biogeochemistry

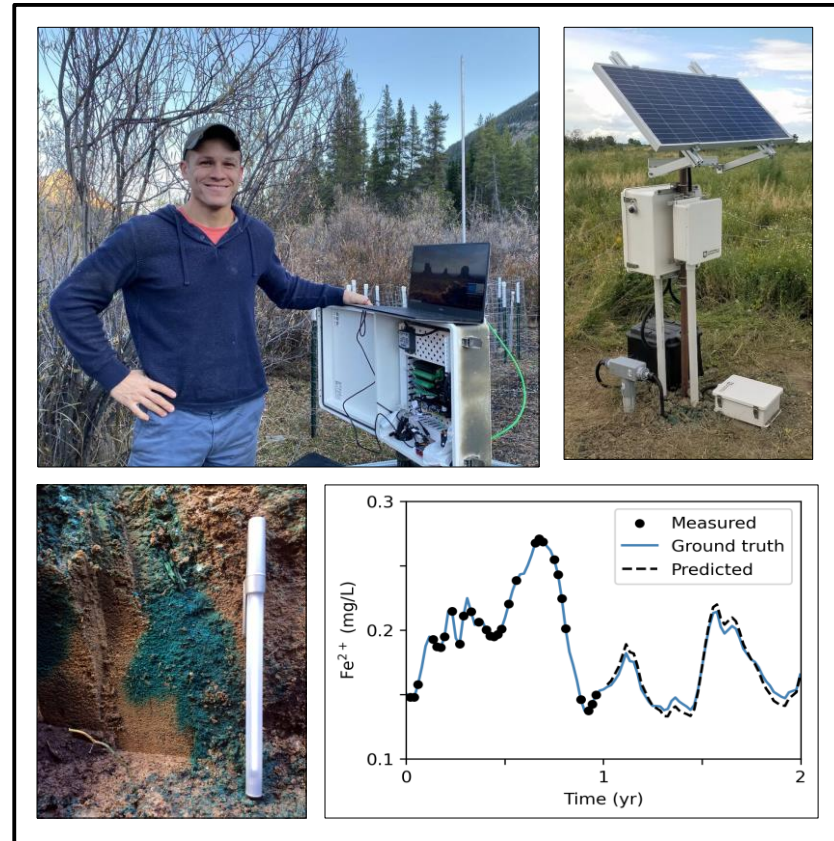

Sensor arrays deployed in Colorado (top left) and Wyoming (top right) allow us to monitor sudden changes in water quality during floods. By pairing these with field experiments – such as tracer tests (bottom left) – we can develop data-driven water quality forecasts (bottom right).

Active Galactic Nuclei

Dr. Daniel Proga

Department of Physics and Astronomy

Phone: (702) 895 3507

Email: dproga@physics.unlv.edu

Expertise:

Radiation-Magnetohydrodynamics

Accretion Physics

Radiation Transfer & Photoionization

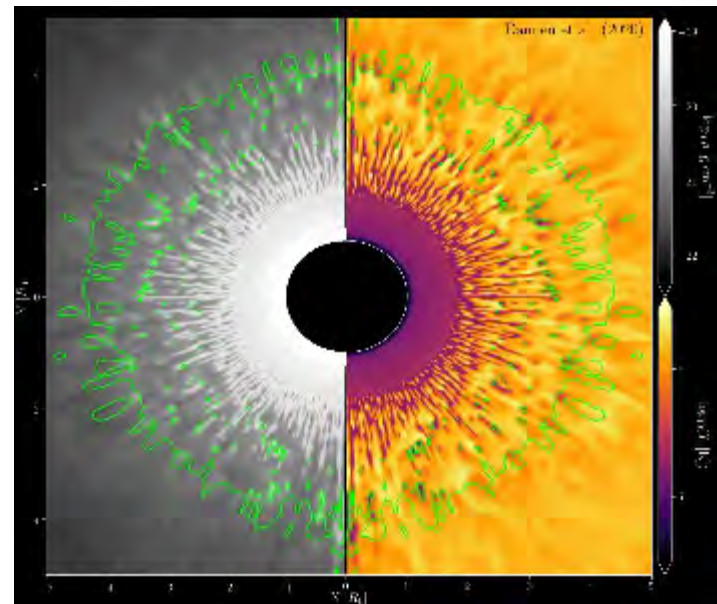

Radiation-hydrodynamic simulations of black hole accretion and related outflows

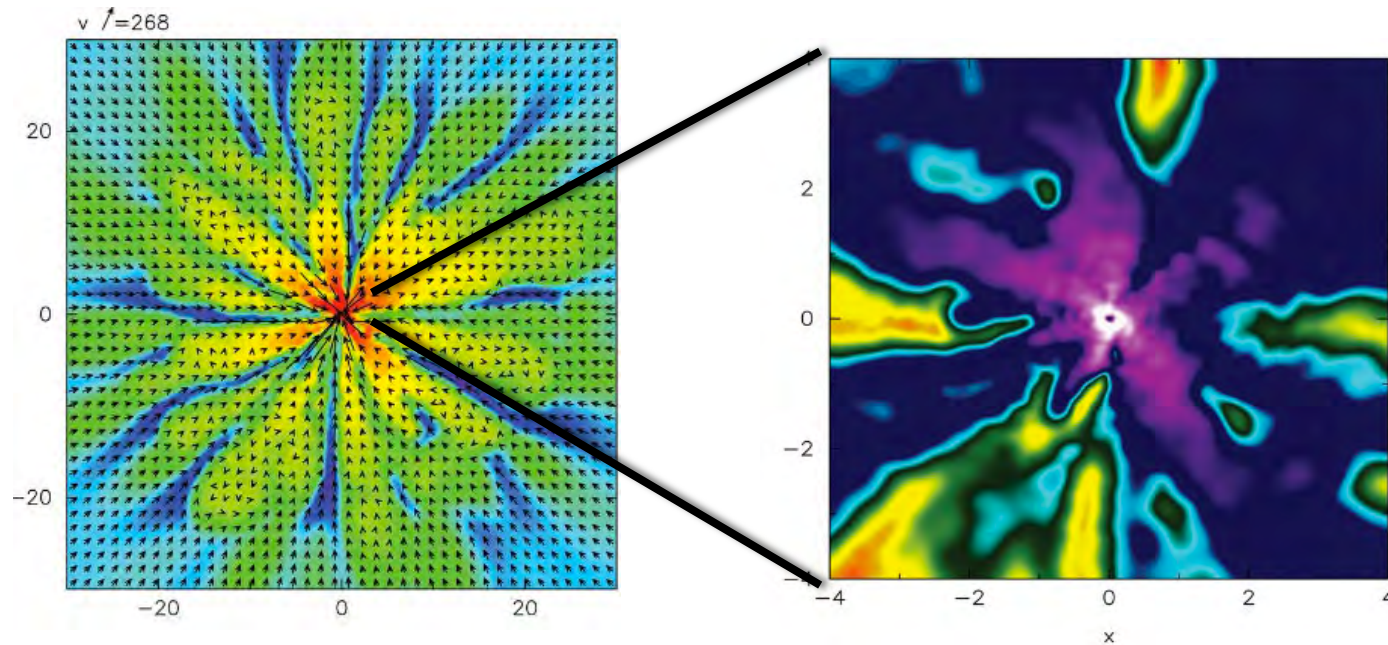

Generated absorption spectra from simulations

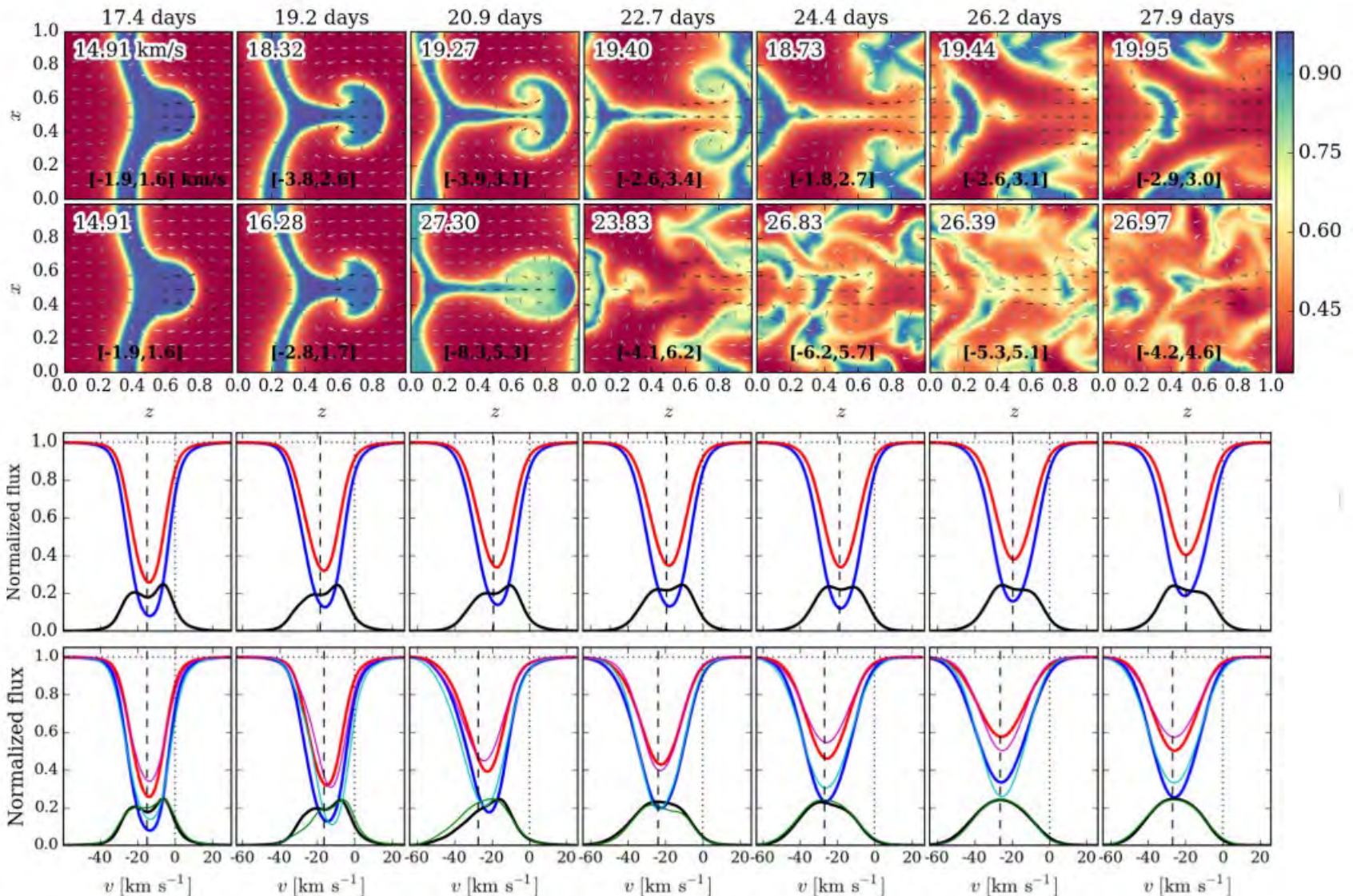

Computational biology and the physiology of plants

Dr. Paul J Schulte

Associate Professor,
School of Life Sciences
Email: paul.Schulte@unlv.edu

Expertise

- Plant water relations and transport processes
- Computational fluid dynamics
- Anatomy of transport tissues in plants

Fluid dynamics of flow between cells

Computer models and mathematical approaches to studying transport processes can help us understand the roles that these structures play in the flow of water from roots to the leaves of tall trees.

These images show work based on a computational fluid dynamics approach to flow through pits in conifer tracheids.

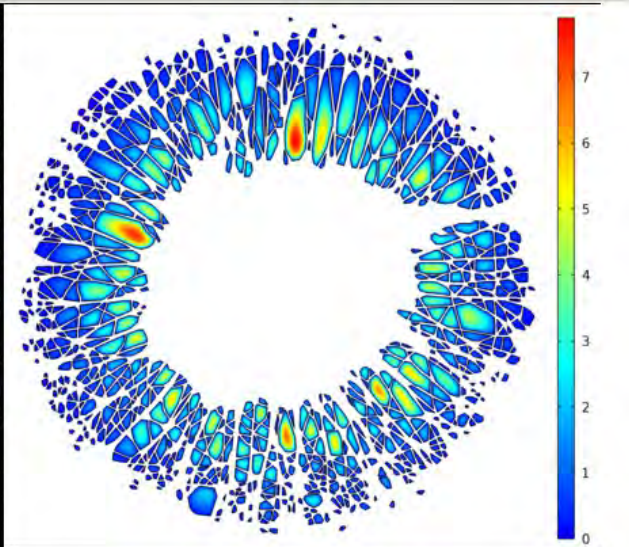
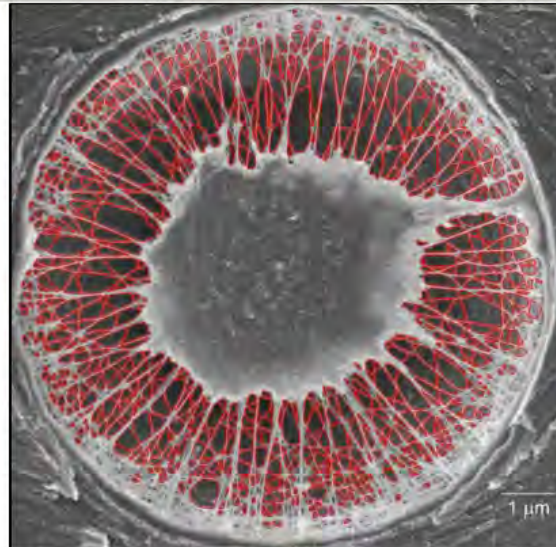
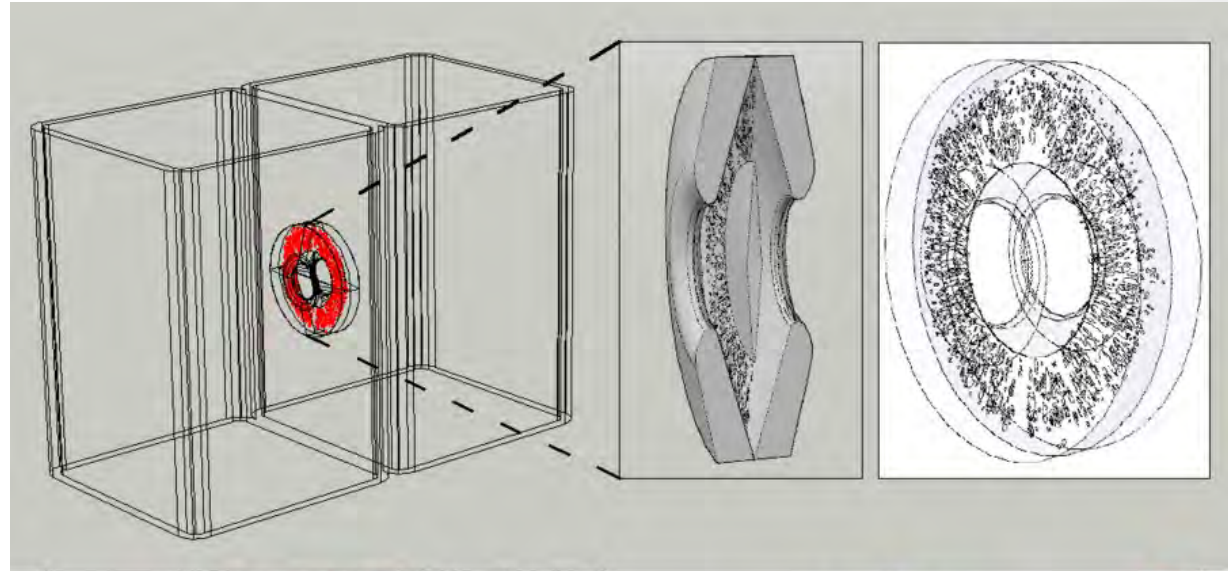

Biomechanics of valves in plant cells

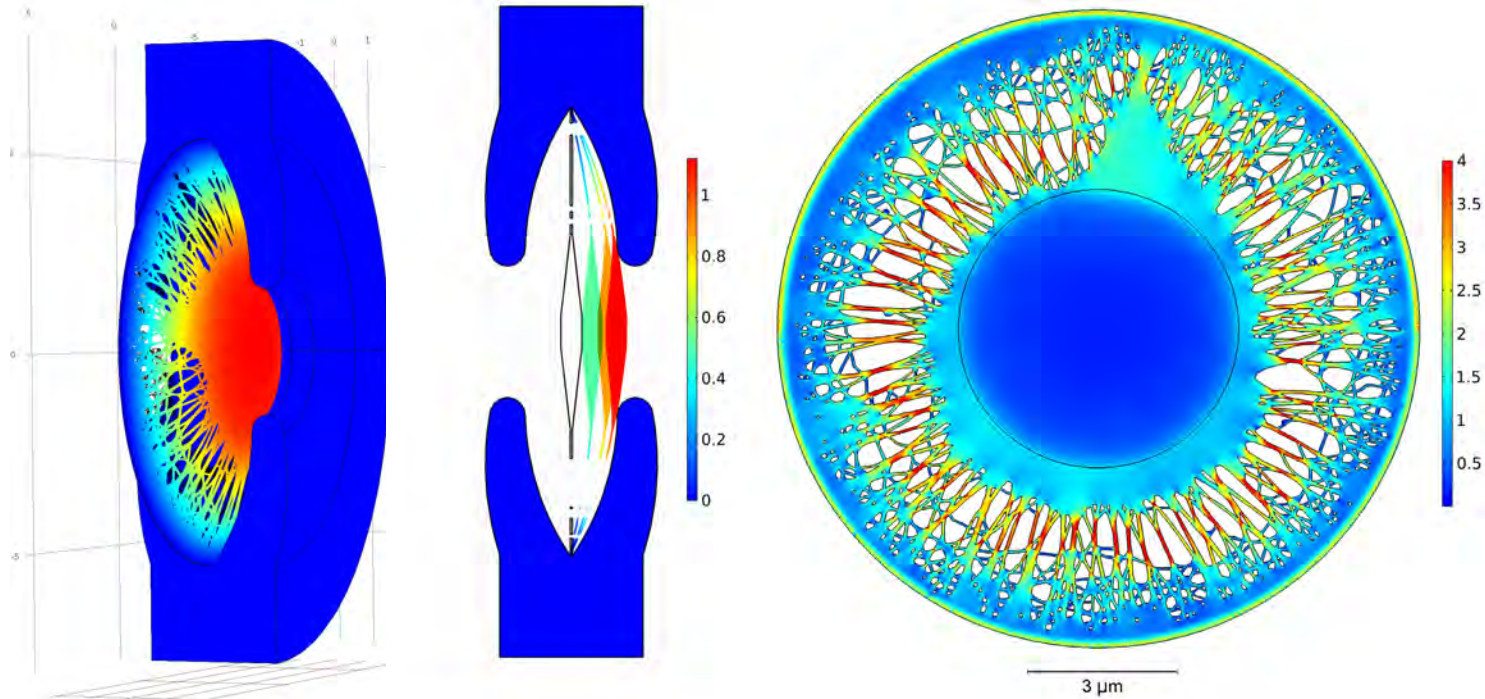

Water flows along the xylem in conifer trees from cell-to-cell through small openings called pits. The pits in many species contain structures that appear to act as valves that prevent air from spreading and blocking the transport system. The above figures show results from solid mechanics modeling of the pressures that are required to deflect the valve and seal the pit.

Advanced Numerical Methods for Moving Domain/Interface Multi-Physics Problems

Dr. Pengtao Sun

Professor

Department of Mathematical Sciences

Email: pengtao.sun@unlv.edu ; URL: <https://faculty.unlv.edu/sun/>

Expertise

- Numerical Solutions of Partial Differential Equations (PDE)
- Numerical Analysis (Well-posedness, Stability, Convergence)
- Finite Element/Volume/Difference Methods
- Scientific and Engineering Computing
- Fluid-Structure Interaction (FSI) Modeling and Simulation
- Fuel Cell Dynamics, Fluid Dynamics, Electrohydrodynamics

Fluid-Hydro Turbine Interaction Problems

- Hydroelectric power generating system produces renewable energy and remains crucial for society and industry. The most significant part of this system is the hydro turbine interacting with the water flow, which involves elastic solid materials and viscous fluids and belongs to the category of fluid-structure interaction (FSI). The developments of mathematical models and numerical methodologies are critical in practice for efficient simulations of the hydro turbine, which in turn guides the design and evaluation.
- We approach the challenges in different aspects. First, based on the observation that the hydro turbine, although exhibiting large rotations, has relatively small deformation, we develop linearized elasticity equations that alleviate the burden on nonlinear solver and improves the well-posedness of spatial discretization. Second, we propose a new approach to solve the arbitrary Lagrangian-Eulerian mesh motion for rotating structure. Moreover, we analyzed the well-posedness and convergence of the finite element discretization and demonstrated the discretization is solver friendly.

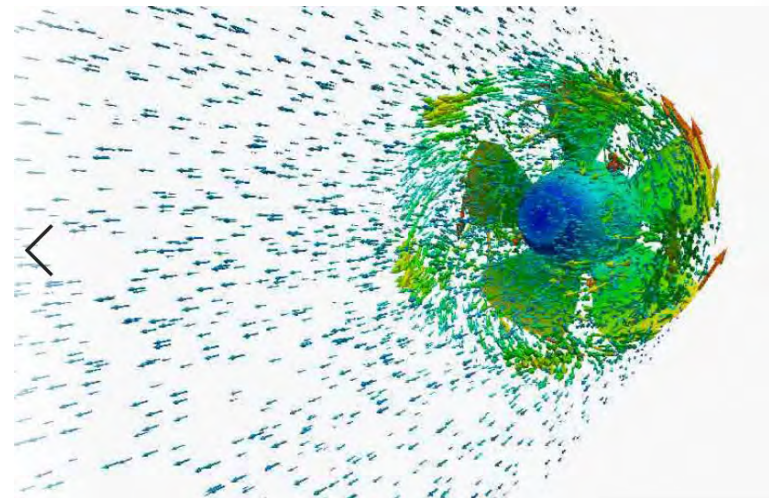
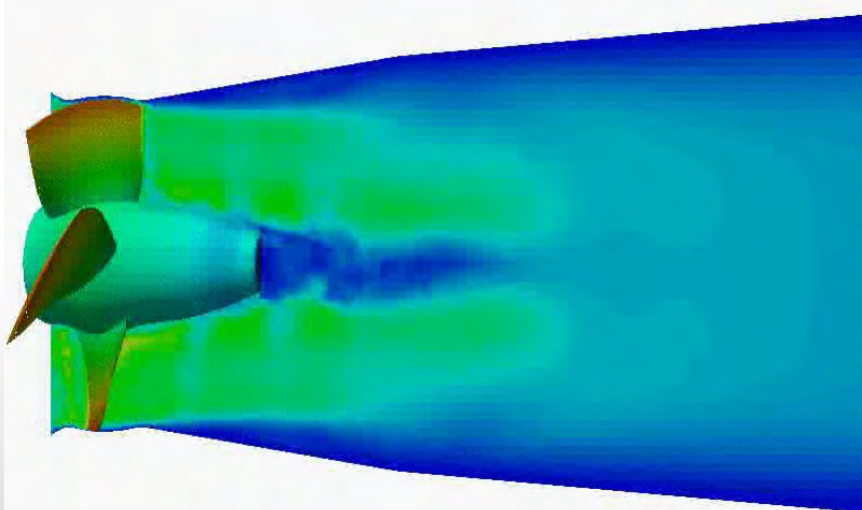

Hemodynamic Fluid-Structure Interaction (FSI) Problems

- FSI simulation has become the most promising solution method to solve the hemodynamic problem existing in the clinical cardiovascular system. However, the complexity of cardiovascular environment, the artificial heart pump model, the vascular rupture, the aneurysm progression and the aortic dissection cause the deficiency of the existing FSI simulation package towards the clinical demands.
- We devoted our research to the new modeling and numerical techniques for the bloodstream-vascular-stent graft/artificial heart pump interaction problems, aiming at overcoming numerical difficulties and challenges, and developed advanced numerical methodologies to improve the efficiency and accuracy of corresponding FSI simulations. and to deliver more instructive numerical results to medical professionals for helping out patients on an efficient and accurate diagnosis and treatment.

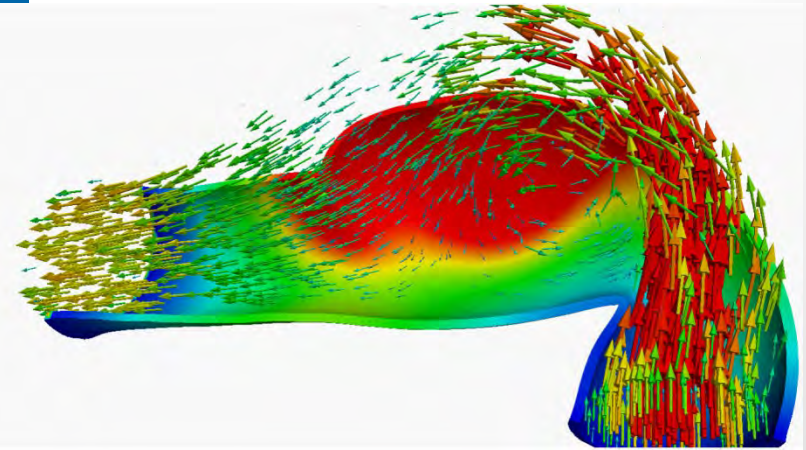
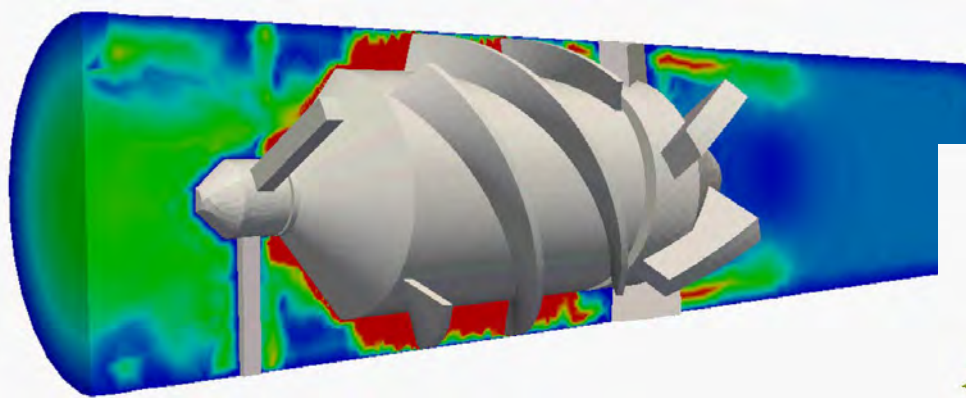

Computational Materials Science

- **Dr. Luqing Wang**
- Assistant Professor - Physics
- Department of Physics and Astronomy
- Email: luqing.wang@unlv.edu
- Office: BPB 232



Expertise

- Density functional theory calculations and machine learning.
- Two-dimensional (2D) materials functionalization and quantum effect.
- Electronic, mechanical, thermodynamic, chemical and optical properties of materials.
- Energy conversion & sustainability.

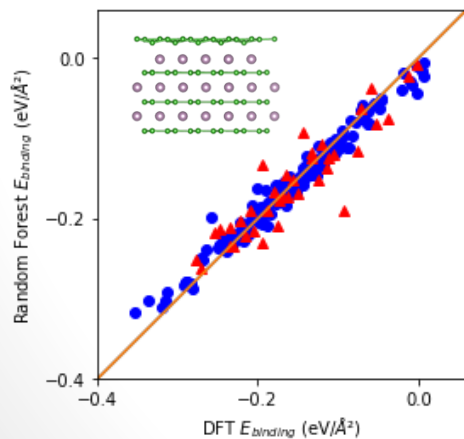

2D Materials Synthesis

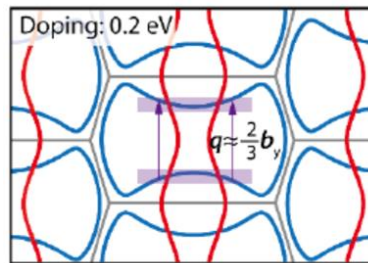

2D Electronic and Quantum

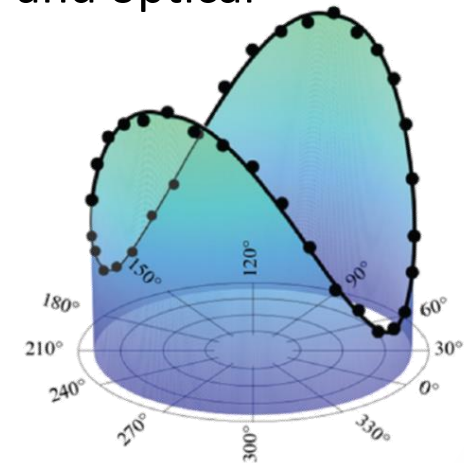

2D Electro-Mechanics

Understand cancer from an embryonic prospective

Dr. Mo Weng

Assistant Professor

School of Life Sciences

Phone: 702-895-5704

Email: mo.weng@unlv.edu

Expertise

- Epithelial-mesenchymal transition
- Developmental genetics
- mechanobiology
- Cancer biology

Understand cancer from an embryonic prospective

- Metastasis, the cause of death for 90% cancer patients, is not a cancer invention but a hijacked natural program essential for generating diverse structures in embryos, called epithelial-mesenchymal transition (EMT).

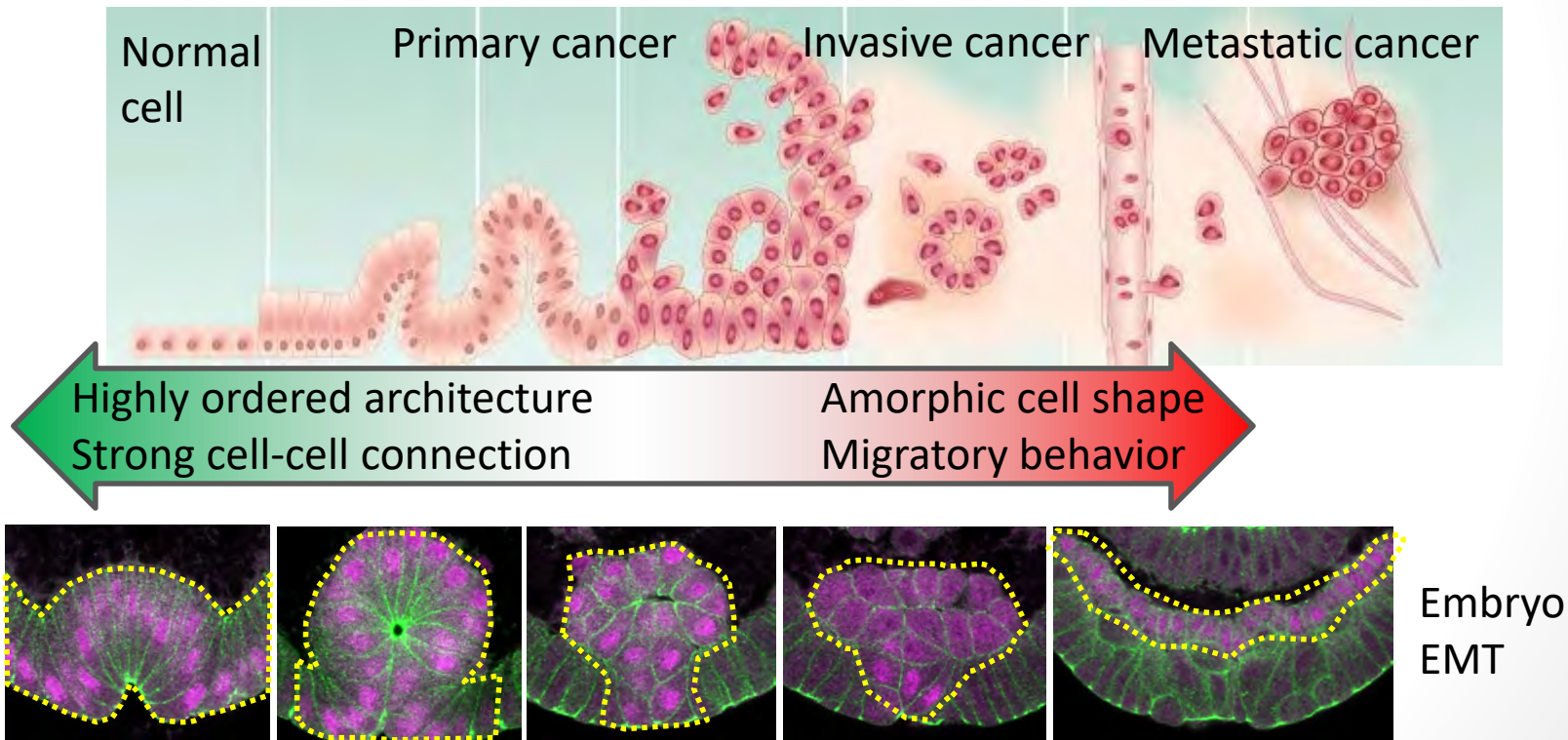

Understand cancer from an embryonic prospective

We use multidisciplinary approaches to study both biochemical and mechanobiological pathways controlling cell polarity and cell fate.

- Seeing is believing: Laser scanning confocal imaging probes micrometer cellular structures in 3D at high resolution and sensitivity
- Live cell imaging records the dynamics of cells and proteins as the living embryo taking on increasingly complex structures.
- Machine-learning approaches extract invisible principles from information-rich images and make predictions
- Genetic approaches such as gene editing test the roles of individual genes and their interaction.

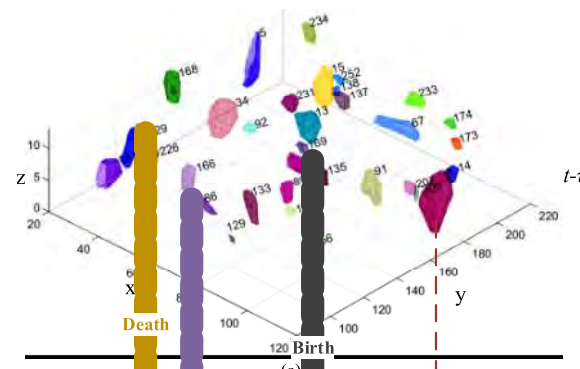
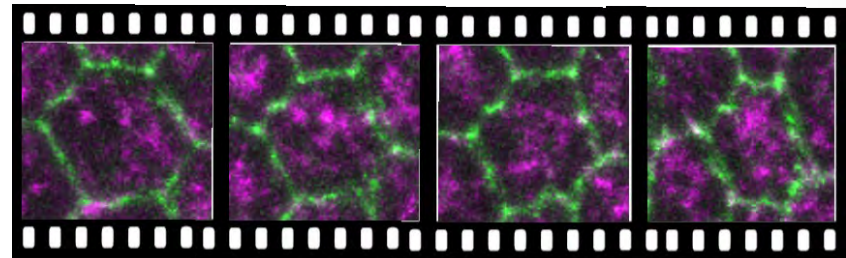
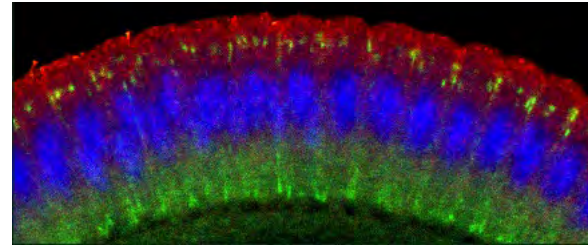

Multi-Messenger High Energy Astrophysics

Dr. Bing Zhang

Department of Physics and Astronomy

Phone: (702)895-4050

Email: zhang@physics.unlv.edu, bing.zhang@unlv.edu

Expertise:

Theoretical astrophysics

Transients (gamma-ray bursts, fast radio bursts, etc) astrophysics

Multi-messenger (EM, gravitational waves, neutrinos, etc) astrophysics

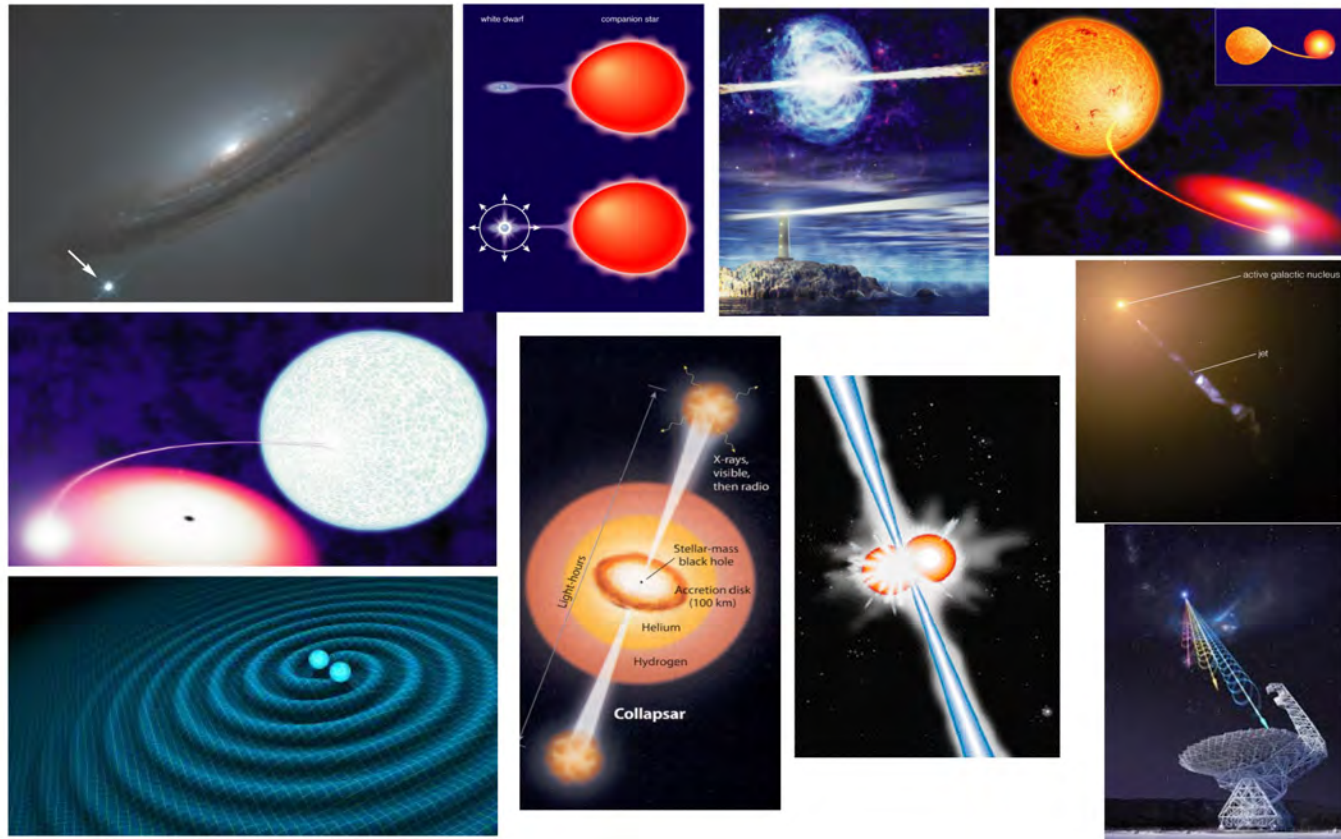

- Dr. Zhang's research covers a broad spectrum in **high-energy** astrophysics. He studies **black holes** of different scales, **neutron stars** of different species, and intense **jets** they launch. He is most actively working on the following three directions:
 - **Gamma-ray bursts** (the most luminous explosions in the universe)
 - **Electromagnetic counterparts** of gravitational waves
 - **Fast radio bursts** (a mysterious type of radio bursting signal)

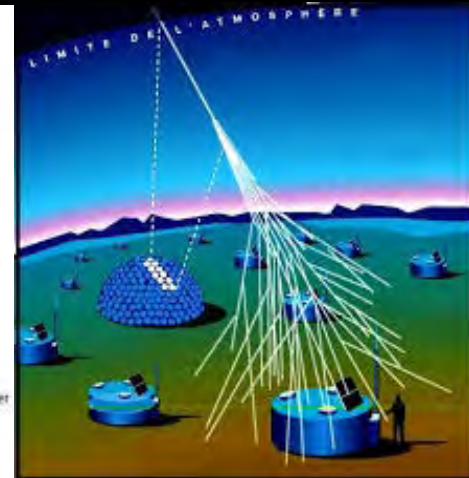
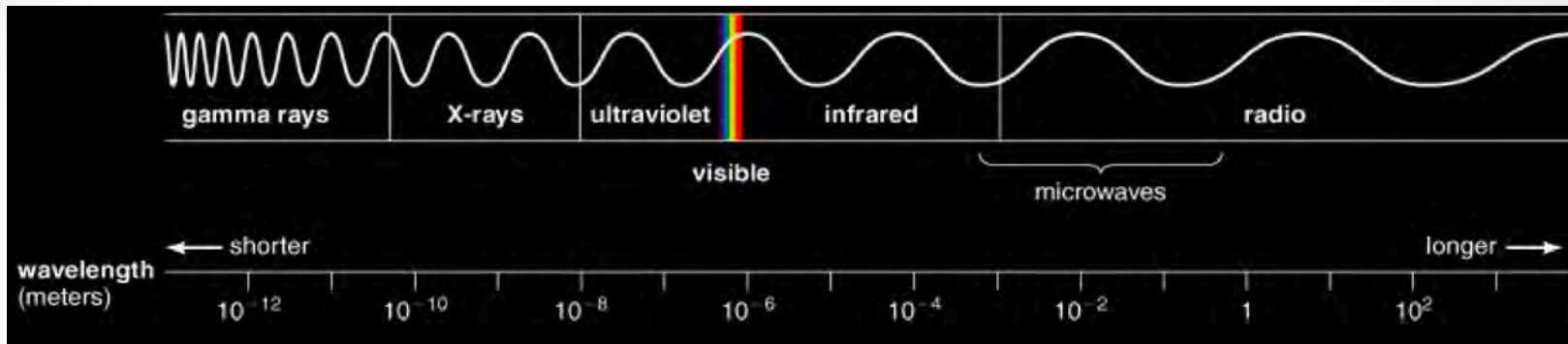

- In terms of observational data, Dr. Zhang's theoretical work make use of multi-wavelength and multi-messenger data:
 - **Multi-wavelength**: across the entire electromagnetic spectrum (from MHz radio waves to TeV gamma-rays)
 - **Multi-messenger**: Besides the traditional electromagnetic radiation, also include gravitational waves, neutrinos, and cosmic rays.

Zhou Lab – Experimental AMO physics

- **Dr. Yan Zhou**
- Assistant Professor
- Department of Physics and Astronomy
- Email: yan.zhou@unlv.edu
- Website: <https://www.physics.unlv.edu/~yanzhou/index.html>

Research projects

- Explore new physics beyond the Standard Model by precision measurements using quantum logically controlled molecular ions
- Precision metrology and spectroscopy using optical frequency combs
- Quantum transducer – link ion trap and superconducting quantum computers
- Experimental astrochemistry – cold ion-radical collisions

Search for T, P -odd symmetry violation

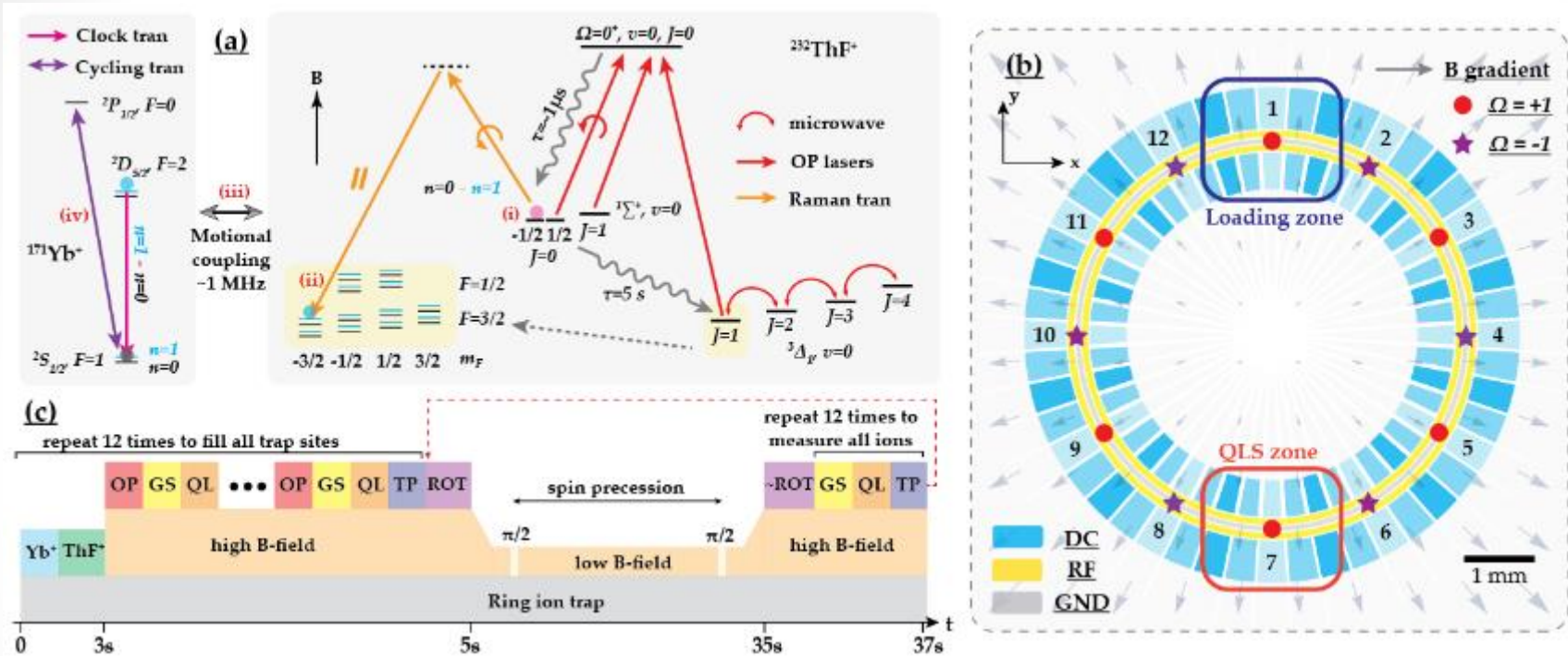

- On-chip Quantum sensors
- Entanglement between atomic ions and molecular ions
- Scalability and multiplexing measurements
- New table-top platform to investigate nuclear physics

Astrophysical Fluid Dynamics

Dr. Zhaohuan Zhu

Department of Physics and Astronomy

Phone: (702) 895- 3563

Email: zhaohuan.zhu@unlv.edu

Expertise:

Fluid dynamics for astronomical project

Star and planet formation

Fluid dynamics:

- Developing and using the state of the art numerical code to solve astrophysical fluid problem.

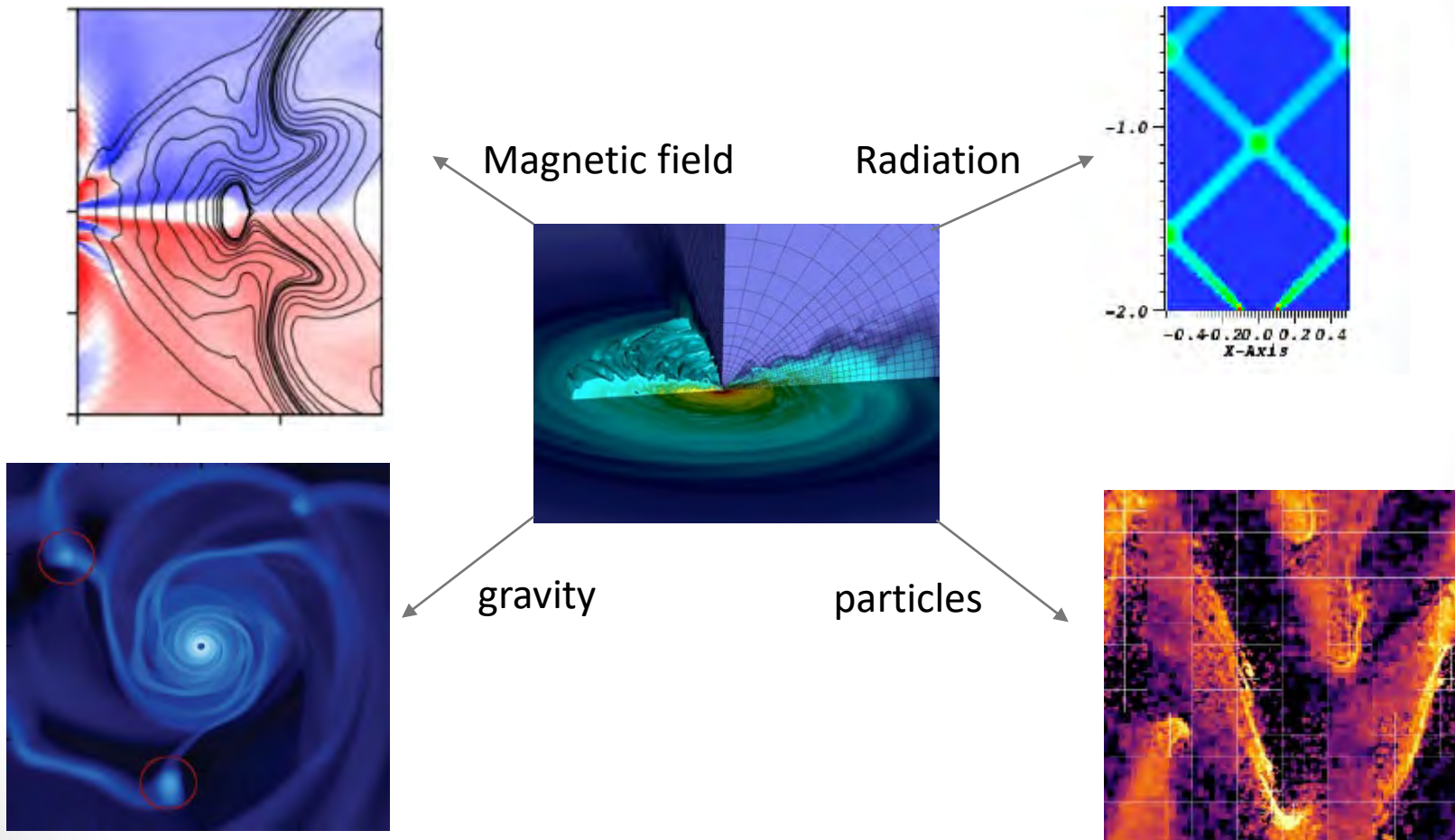

Star and planet formation:

- Protoplanetary disk dynamics:

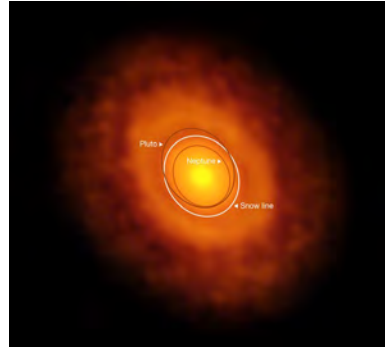

V883 Ori, *Nature*

- Planet formation

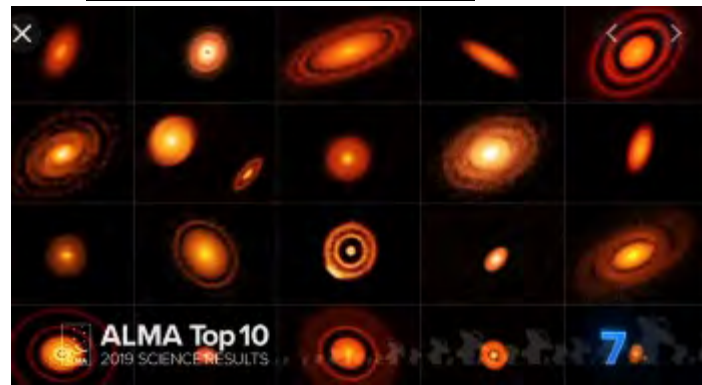

DSHARP

- Planet-disk interaction

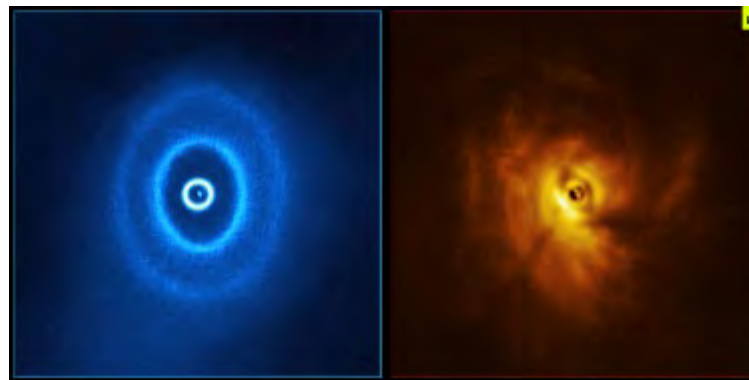

GW Ori, *Science*

Bernard Zygelman

- Quantum Computing and Information
- Computational Physics
- Atomic and Molecular Processes in Plasmas
- Quantum Workforce Development

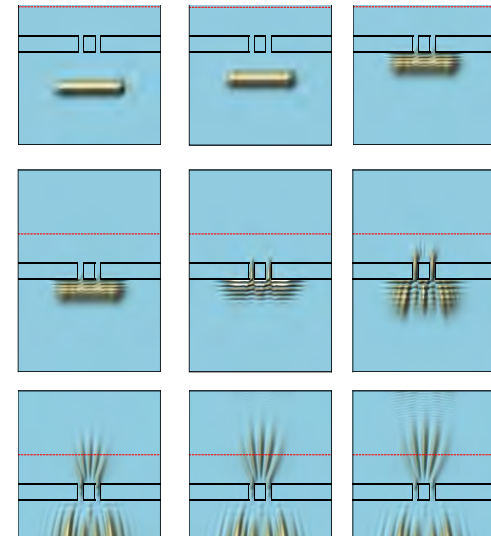
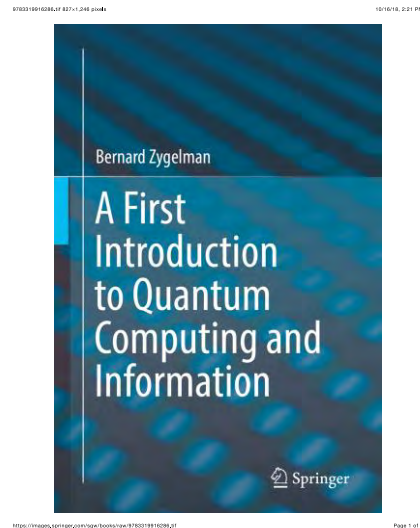

Research Expertise and Activities

- Over 70 publications, h-index 27-Google Scholar
- Work funded by AFOSR, DOE, IAEA, NSF, NASA, W. M. Keck Foundation
- Topics include remote sensing of the thermosphere, matter-anti-matter interactions, QED, radiative and non-radiative charge transfer in hot plasmas, atomic processes in the early universe, ultra-cold physics, geometric phase and magnetism, quantum computing and information

Relevant Publications

1. B. Zygelman, *Appearance of gauge potentials in atomic collision physics*, Physics Letters A, 125, 476, 1987; (Re-printed in Geometric Phases in Physics ed. A. Shapere and F. Wilczek (Nobel laureate in Physics)).
2. Sharma, R, Zygelman, von Esse, F., Dalgarno, A., *Geophys. On the relationship between the population of the fine structure levels of the ground electronic state of atomic oxygen and the translational temperature*, Geophysics Res. Lett., 21, 1731, 1994
3. Stancil, P. C. and Zygelman, B., *Kinematic Isotope Effects in Low Energy Electron Capture*, Phys. Rev. Lett. 75, 1495, 1995
4. Zygelman, B. Saenz, A. Froelich, P. and Jonsell, S., *Cold collisions of atomic hydrogen with anti-hydrogen atoms: An optical potential approach*, Phys Rev A. 69, 042715, 2005
5. Zygelman, B. *Hyperfine Level-changing Collisions of Hydrogen Atoms and Tomography of the Dark Age Universe*, Ap. J, 622, 1356, 2005
6. Zygelman B. Lucic Z., and Hudson E., *Cold ion-atom chemistry driven by spontaneous radiative relaxation: a case study for the formation of the YbCa+molecular ion*, J. Phys. B 47, 015301, 2013
7. B. Zygelman, *Geometric-phase atom optics and interferometry*, Phys. Rev. A., 92, 043620, 2015
8. B. Zygelman, *A First Introduction to Quantum Computing and Information*, Springer-Nature, 2018.